

5 DIGIT LOOP-POWERED PANEL METERS WITH LOOP-POWERED BACKLIGHT

**Loop Leader**[®]
Series



Model PD683 General Purpose



Model PD688 Hazardous Area



Model PD688 Only

- 4-20 mA Input
- 5 Digit LCD, 0.6" (15.2 mm) High
- FM Type 4X, IP65 Front
- Shallow Depth Case 3.2" Behind Panel
- 2 V Drop (5.7 V with Backlight)
- Loop-Powered Backlight Standard
- Custom Engineering Units & Bargraph
- Linear, Square Root, or Programmable Exponent
- Maximum & Minimum Display
- Operating Temperature Range -30 to 65°C
- Intrinsically Safe & Non-Incendive
- HART Protocol Transparent

INSTRUMENTS • CONTROLS • VALVES

[CLICK TO VISIT OUR WEBSITE](#)

 3317 Gilmore Industrial Blvd.
Louisville, KY 40213

Ph: (502) 966-3134
Fx: (502) 966-3135

www.arcoengineering.com

PRECISION DIGITAL CORPORATION

**PRECISION
DIGITAL** 
www.predig.com



Actual Size

KEY FEATURES

Through significant innovation in technology and design, we developed the Loop Leader® Series of loop-powered indicators, which are loaded with standard features and built for tough industrial environments.

Full Featured

There's nothing stripped down or bare bones about these indicators; they're designed for demanding process control applications. Standard features include a full 5 digit backlit display with bargraph, on-screen custom engineering units, and max/min display capabilities

Install Just About Anywhere

Indoors, outdoors, bright sunlight, dimly lit plant, wet, dirty, hot or cold, these indicators go just about anywhere. Their shallow-depth case, FM Type 4X front, loop-powered backlighting, and wide operating temperature range are all standard features. And the PD688 with its FM Approval and CSA and ATEX Certifications can be installed in just about any hazardous location.

4-20 mA Input Connections

Wiring with Backlight

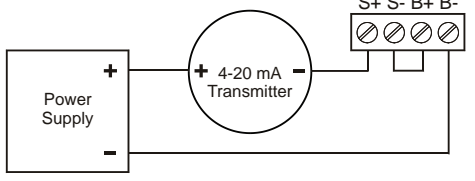

Wiring without Backlight

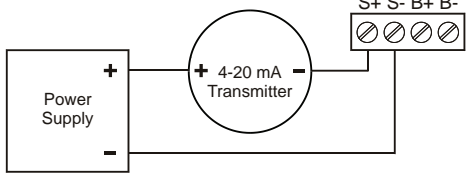

Square Root Function

The square root extraction feature displays flow rate by extracting the square root from a differential pressure transmitter signal. The user selectable low-flow cutoff feature gives a reading of zero when the flow rate drops below a user selectable value.

- Displays Flow Rate
- User Selectable Low-Flow Cutoff
- Only 2 Calibration Points Required

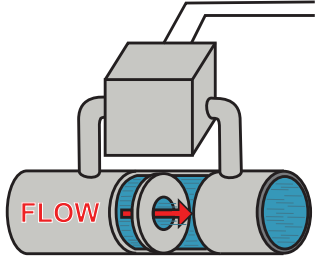

Programmable Exponent

The programmable exponent function is used to linearize the level signal in open channel flow applications using weirs and flumes and display flow rate in engineering units.

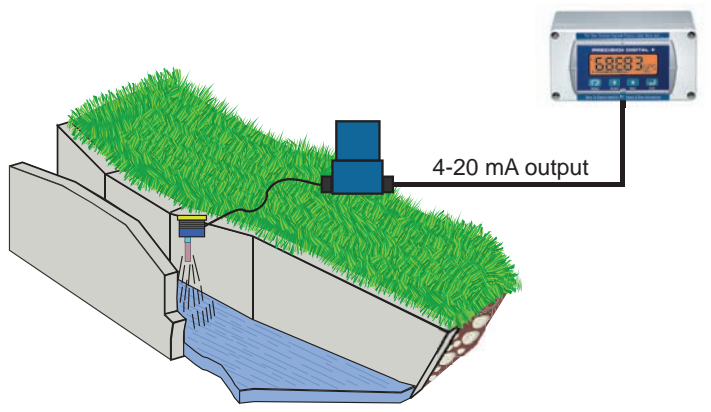

SETUP & PROGRAMMING

Easy Setup

Even with all the features packed into these meters, they're still easy to setup and get running. Everything is programmed from the front panel buttons with no pots or jumpers to deal with. In fact, these meters can be scaled without a signal source for even quicker setup.

Main Menu

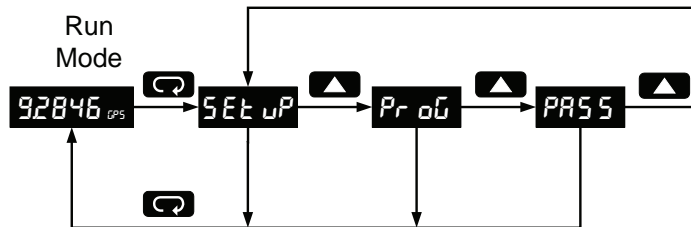

Advanced Features Menu

To simplify the setup process, functions not needed for most applications are located in the Advanced Features menu. Press and hold the Menu button for five seconds to access the advanced features of the meter.

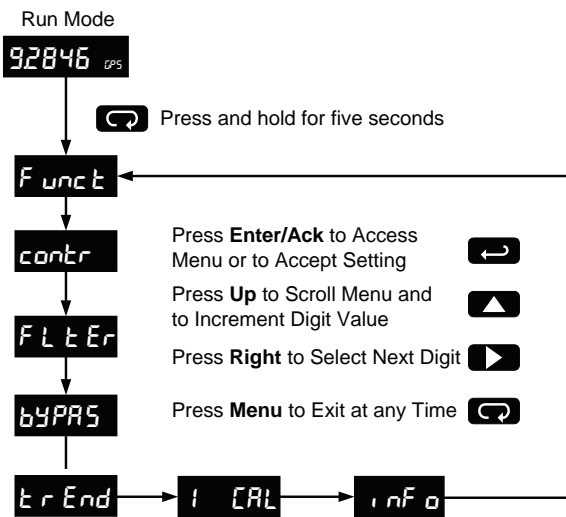

INSTALLATION

There is no need to remove the meter from its case to complete the installation, wiring, and setup of the meter.

Mounting Dimensions

Units: Inch (mm)

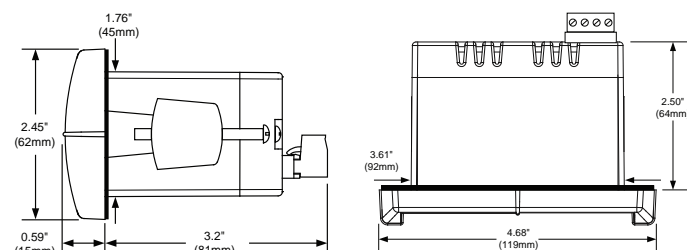

Notes:

1. Panel cutout required: 3.622 x 1.772 (92 x 45)
2. Panel thickness: 0.040 – 0.250 (1.0 – 6.4)
3. Mounting brackets lock in place for easy mounting

PD688 Intrinsically Safe Wiring

Installation must be performed in accordance with Control Drawing LIM688-2.

Loop Input with Backlight

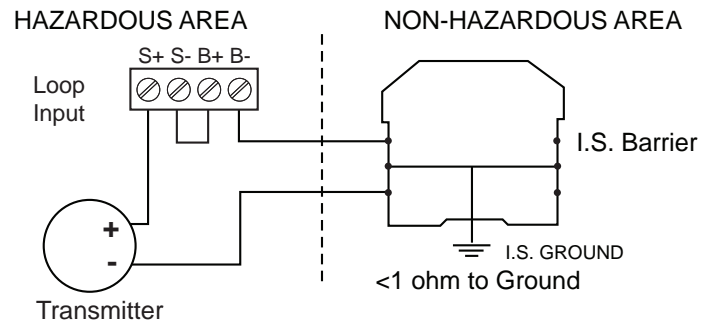

Loop Input without Backlight

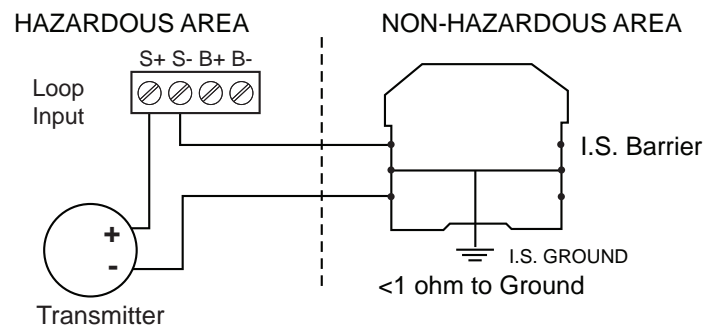

OPTIONAL ENCLOSURES



PDA2801 low-cost NEMA 4X enclosure for one PD683 meter



NEMA 4X enclosures are available in plastic, steel, & stainless steel for one to six PD683 meters

Go to www.predig.com for complete details

SPECIFICATIONS

Except where noted all specifications apply to operation at +25°C.

General

- Display:** 5 digit LCD (-99999 to 99999), 0.60" (15.2 mm) high, 7-segment, automatic lead zero blanking.
- Engineering Units:** 0.25" (6.4 mm) high, 14-segment
- Bargraph:** 20-segment, 0-100% indication
- Trend Arrows:** Up and down trend indication
- Backlight:** Bright orange LED (intensity varies with signal)
- Front Panel:** FM Type 4X, IP65; panel gasket provided
- Display Update Rate:** 2.5/second
- Overrange:** Display flashes 99999
- Underrange:** Display flashes -99999
- Programming Method:** Four front panel buttons
- Noise Filter:** Programmable from 1 to 199
- Recalibration:** Recommended at least every 12 months
- Max/Min Display:** Max/min readings reached by the process are stored until reset by the user or until power to the meter is turned off.
- Password:** Programmable password restricts modification of programmed settings.
- Non-Volatile Memory:** All programmed settings are stored in non-volatile memory for a minimum of ten years if power is lost.
- Voltage Drop:** 2.0 V max w/o backlight, 5.7 V max with backlight
- Equivalent Resistance:** 100 Ω @ 20 mA without backlight, 285 Ω @ 20 mA with backlight.
- Normal Mode Rejection:** 64 dB at 50/60 Hz
- Operating Temperature Range:** -30 to 65°C
- Allowable Temperature Range:** -40 to 65°C† (see note below)
- Storage Temperature Range:** -40 to 85°C
- Relative Humidity:** 0 to 90% non-condensing
- Connections:** Screw terminals accept 12 to 22 AWG wire
- Enclosure:** 1/8 DIN, high impact plastic, UL 94V-0, color: gray
- Mounting:** 1/8 DIN panel cutout required. Two panel mounting bracket assemblies provided.
- Tightening Torque:** 4.5 lb-in (0.5 Nm) Screw terminal connectors
- Overall Dimensions:** 4.68" x 2.45" x 3.79" (119 x 62 x 96 mm)
- Weight:** 5.7 oz (162 g)
- Warranty:** 3 years parts and labor

† Below -30°C the LCD becomes less readable. See application note AN-1005.

Input

- Input Range:** 4-20 mA
- Accuracy:** ±0.03% of span ±1 count, square root and programmable exponent: 10-100% FS.
- Calibration:** Scale without signal or calibrate with signal source
- Calibration Range:** User programmable over entire range of meter
- Minimum Span:** 0.40 mA between input 1 and input 2
- Note:** An Error message will appear if input 1 and input 2 signals are too close together.
- Input Overload:** Over current protection to 2 A maximum
- Decimal Point:** Up to 4 places (d.dddd, dd.ddd, ddd.dd, dddd.d, or ddddd)
- Function:** Linear, square root, or programmable exponent
- Low-Flow Cutoff:** -99999 to 99999 (-99999 disables cutoff function)
- Temperature Drift:** 50 PPM/°C from -40 to 65°C ambient

PD688 Approvals for Hazardous Locations

FM Approved & CSA Certified: Intrinsically safe with entity for use in Class I, Div 1, Groups ABCD; Class II, Div 1, Groups EFG; Class III, Div 1; Class I, Zone 0, Group IIC; T-code = T4. Non-incendive: Suitable for use in Class I, Div 2, Groups ABCD; Class II, Div 2, Groups FG; Class III, Div 2.

Entity Parameters: U_i : 30 V; I_i : 175 mA; C_i : 0; L_i : 0; P_i : 1.0 W

ATEX Certified: II 1G, Ex ia IIC T4, IP65, Ta = -40°C to 65°C

Note: Installation must be performed in accordance with Control Drawing LIM688-2

ORDERING INFORMATION

Loop Leader® • PD683/PD688	
Model	Description
PD683-0K0*	General Purpose
PD688-0K0*	FM Approved, CSA & ATEX Certified

* Quick Shipment Program product, typically shipped within 2 working days

Accessories			
Model	Meters	Description	Mounting
PDA23XX	1 - 10*	Plastic NEMA 4X	Through Door
PDA24XX	1 - 2*	Plastic NEMA 4X	Inside Cover
PDA25XX	1 - 10*	Plastic NEMA 4X	Through Door
PDA26XX	1 - 6*	Stainless Steel NEMA 4X	Through Door
PDA27XX	1 - 6*	Steel NEMA 4X	Through Door
PDA2801	1	Low-Cost NEMA 4X	Through Cover

Note: XX = the last two digits of the model number.

* Go to www.predig.com/esu to find individual model numbers



Your Local Distributor is:

INSTRUMENTS • CONTROLS • VALVES

CLICK TO VISIT OUR WEBSITE



ARCO
Engineering, Inc.
SINCE 1954
www.arcoengineering.com

3317 Gilmore Industrial Blvd.
Louisville, KY 40213

Ph: (502) 966-3134
Fx: (502) 966-3135

Disclaimer

The information contained in this document is subject to change without notice. Precision Digital Corporation makes no representations or warranties with respect to the contents hereof, and specifically disclaims any implied warranties of merchantability or fitness for a particular purpose. ©2010 Precision Digital Corporation. All rights reserved.