



## Features

- The Model 16 Vacuum Regulator is designed for systems that require system pressure control above and below atmospheric pressure.
- Control sensitivity of 1/2" water column allows use in precision applications.
- A balanced Supply Valve minimizes the effects of supply pressure variation.
- An Aspirator Tube compensates downstream pressure droop under flow conditions.
- A separate Control Chamber isolates the diaphragm from the main flow to eliminate hunting and buzzing.
- Unit construction lets you service the Model 16 without removing it from the line.
- Mounting Bracket is available.
- Canadian Registration Number (CRN) Certification for all territories and provinces

## Operating Principles

When you adjust the Range Screw to a specific setpoint, the Range Spring exerts a downward force on the top of the Signal Diaphragm. The Negative Bias Spring creates an upward force on the bottom of the Signal Diaphragm. The upward net force opens the Relief Valve (vacuum supply) to let Vacuum flow from the Outlet Port to the Exhaust Port. As the setpoint is reached, the decrease in pressure lets the Diaphragm Assembly move downward to close the Relief Valve (vacuum supply).

When the Vacuum increases above the setpoint, the Diaphragm Assembly moves downward to open the Supply Valve that adds positive pressure to the system to maintain Output pressure. For more information, see cross sectional diagram.

Outlet pressure is maintained as a result of balance between forces acting on the top and bottom of the Diaphragm Assembly.

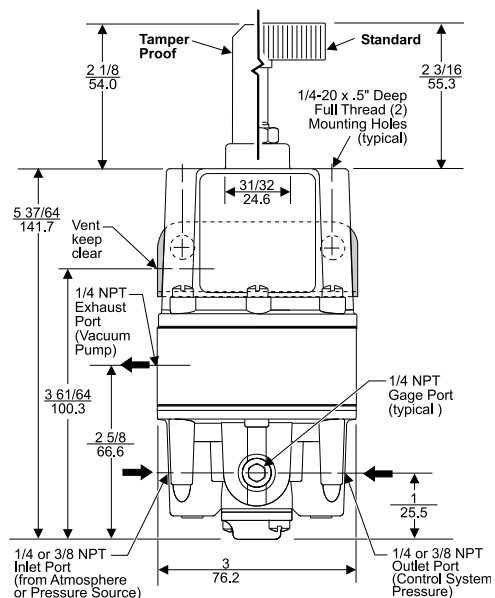
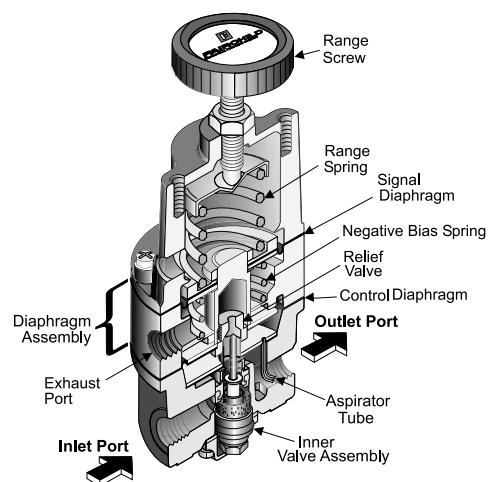

INSTRUMENTS • CONTROLS • VALVES

CLICK TO VISIT OUR WEBSITE

**ARCO**  
Engineering, Inc.  
SINCE 1954  
www.arcoengineering.com

3317 Gilmore Industrial Blvd.  
Louisville, KY 40213

Ph: (502) 966-3134  
Fx: (502) 966-3135

**Technical Information**

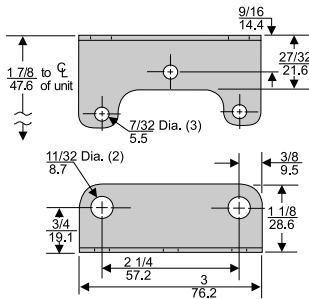
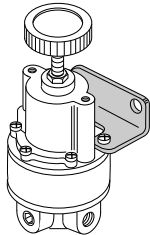
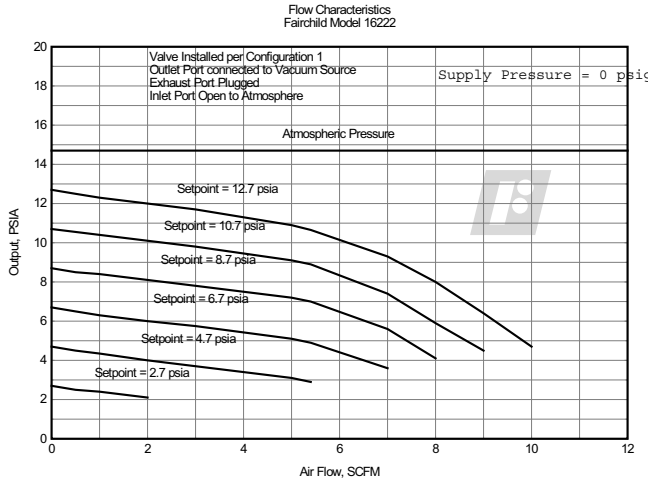

**Model 16 Regulator Kits & Accessories**

Mounting Bracket Kit . . . . .09921 (sold separately)

**Specifications**

**Supply Pressure**

250 psig, [17.0 BAR], (1700 kPa) Maximum

**Positive Flow Capacity (SCFM)**

40 (65.2 m<sup>3</sup>/HR) @ 100 psig, [7.0 BAR] supply,  
(700 kPa) supply & 20 psig, [1.5 BAR], (150 kPa) setpoint

**Vacuum Flow Capacity (SCFM)**

2.5 (4 m<sup>3</sup>/HR) @ 29" Hg VAC with pump connected to  
exhaust port  
40 (65.2 m<sup>3</sup>/HR) @ 100 psig supply connected to inlet port

**Supply Pressure Effect**

Less than 0.1 psig, [.007 BAR], (0.7 kPa) for 100 psig,  
[7.0 BAR]. (700 kPa) change in supply pressure

**Sensitivity**

1/2" (1.27 cm) Water Column

**Ambient Temperature**

-40°F to +200°F, (-40°C to +93.3°C)

**Materials of Construction**

Body and Housing . . . . .Aluminum  
Trim . . . . .Stainless Steel, Brass and Zinc Plated Steel  
Diaphragms . . . . .Nitrile on Dacron

**Hazardous Locations**

Acceptable for use in Zones 1 and 2 for gas atmosphere;  
Groups IIA and IIB and Zones 21 and 22 for dust atmospheres

**Catalog Information**

**Catalog Number**

**1 6**

**Model 16**

**Pressure Range**

psig	[BAR]	(kPa)
Vacuum - 2	[Vacuum -0.15]	(Vacuum - 15)
Vacuum - 10	[Vacuum -0.7]	(Vacuum - 70)
Vacuum - 30	[Vacuum -2.0]	(Vacuum - 200)
Vacuum - 100	[Vacuum -7.0]	(Vacuum - 700)
Vacuum - 150	[Vacuum - 10]	(Vacuum - 1000)

21	2
22	3
23	4
25	
26	

**Pipe Size**

1/4" NPT . . . . .  
3/8" NPT . . . . .  
1/2" NPT . . . . .

**Options**

Silicone Elastomers <sup>1</sup>	A
BSPP (Parallel) <sup>2</sup>	H
Tamper Proof	T
Fluorocarbon (Viton) Elastomers	J
Increased Sensitivity	L
BSPT (Tapered)	U

<sup>1</sup> Maximum Supply Pressure - 75 psig, [5.0 BAR], (500 kPa)

<sup>2</sup> BSPP Threads in Inlet & Outlet Ports Only. Others BSPT.

**Installation**

For installation instructions, refer to the *Fairchild Model 16 Vacuum Regulator Installation, Operation and Maintenance Instructions*, IS-10000016.

**INSTRUMENTS • CONTROLS • VALVES**

CLICK TO VISIT OUR WEBSITE

3317 Gilmore Industrial Blvd.  
Louisville, KY 40213

Ph: (502) 966-3134  
Fx: (502) 966-3135

www.arcoengineering.com