

Bourdon Tube Pressure Gauge Model 213.40 Industrial Series Liquid Filled

INSTRUMENTS • CONTROLS • VALVES

CLICK TO VISIT OUR WEBSITE



3317 Gilmore Industrial Blvd.
Louisville, KY 40213

Engineering, Inc.
SINCE 1954
www.arcoengineering.com

Ph: (502) 966-3134
Fx: (502) 966-3135

Applications

- Intended for adverse service conditions where pulsation or vibration exists
- Suitable for gaseous or liquid media that will not obstruct the pressure system
- Hydraulics & compressors

Special features

- Vibration and shock resistant
- Solid forged-brass case and socket
- Pressure ranges up to 15,000 psi

Standard Features

Design

ASME B40.100 & EN 837-1

Sizes

2½" & 4" (63 & 100 mm)

Accuracy class

2½": ± 2/1/2% of span (ASME B40.100 Grade A)

4": ± 1% of span (ASME B40.100 Grade 1A)

Ranges

Vacuum / Compound to 200 psi

Pressure from 15 psi to 15,000 psi

or other equivalent units of pressure or vacuum

Working pressure

2½": Steady: 3/4 scale value
Fluctuating: 2/3 full scale value
Short time: full scale value

4": Steady: full scale value
Fluctuating: 0.9 x full scale value
Short time: 1.3 x full scale value

Operating temperature

Ambient: -4°F to +140°F (-20°C to +60°C) - glycerine filled
-40°F to +140°F (-40°C to +60°C) - silicone filled

Medium: max. +140°F (+60°C) - soldered system
max. +212°F (+100°C) - brazed system



Bourdon Tube Pressure Gauge Model 213.40

Temperature error

Additional error when temperature changes from reference temperature of 68°F (20°C) ±0.3% for every 18°F (10°C) rising or falling. Percentage of span.

Weather protection

Weather tight (NEMA 4X / IP 65)

Pressure connection

Material: copper alloy

Lower mount (LM) or center back mount (CBM) - 2½"

Lower mount (LM) or lower back mount (LBM) - 4"

1/4" NPT or 1/2" NPT limited to wrench flat area

Bourdon tube

2½" Size- Material: Copper alloy

30" Hg (VAC) to 1,000 PSI- C-type (soldered)

1,500 PSI to 15,000 PSI- helical type (soldered)

4" Size- Material: Copper alloy < 1,000 PSI

316 stainless steel > 1,500 PSI

30" Hg (Vac) to 1,000 PSI- C-type (soldered)

1,500 PSI to 15,000 PSI- helical type (brazed)

Movement

Copper alloy

Dial

White aluminum with black lettering, 2½" with stop pin

Pointer

Black aluminum

Case

Gold-painted forged brass with integral connection and vent plug

Bezel ring

Gold-plated ABS cover ring (2½")
 Chrome-plated brass cover ring (4")

Window

Acrylic with Buna-N gasket

Case fill

Glycerine 99.7%

Optional extras

- Brass restrictor
- Front or rear flange
- U-clamp mounting
- Laminated safety glass or flat glass window
- Red drag pointer or mark pointer
- Silicone or Fluorolube case filling
- Special connections limited to wrench flat area
- Custom dial layout
- Other pressure scales available
 bar, kPa, MPa, kg/cm² and dual scales

Dimensions

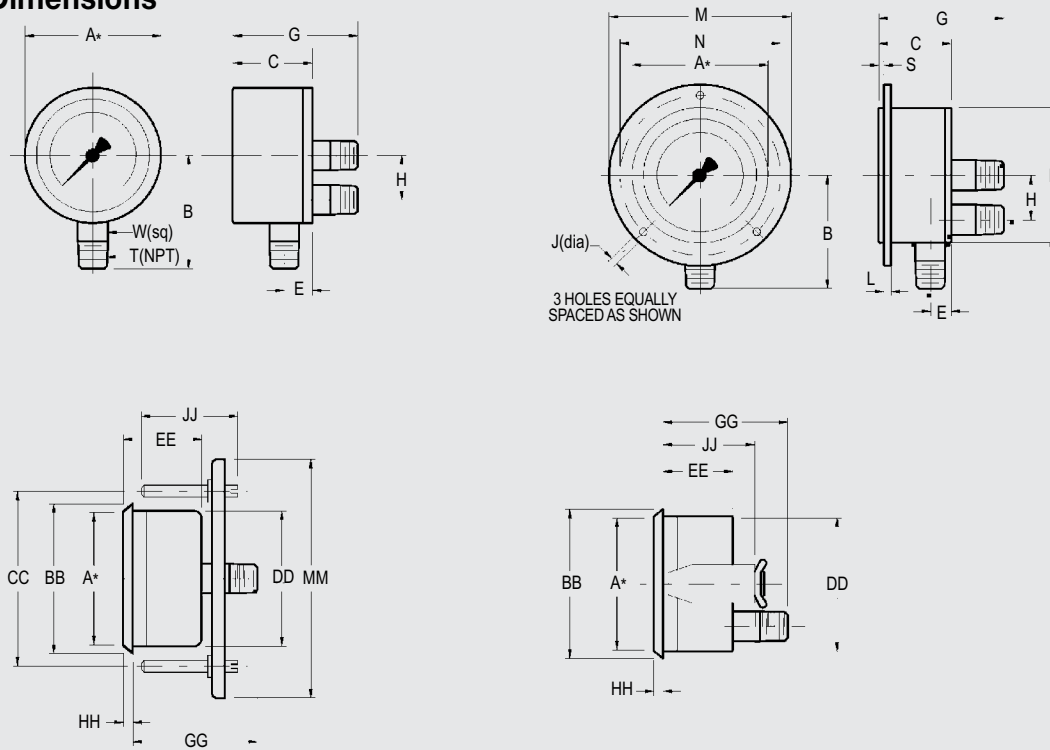

| Size | | A | B | C | D | E | G | H | J | K | L | M | N | O | P | R |
|------|----|-----|------|------|------|------|------|------|------|------|------|------|------|------|------|------|
| 2.5" | mm | 63 | 53 | 37 | 63 | 11 | 63 | - | 3.5 | 14 | 2 | 85 | 75 | 79 | 39 | 5.5 |
| | in | 2.5 | 2.09 | 1.46 | 2.48 | 0.43 | 2.48 | - | 0.14 | 0.55 | 0.08 | 3.35 | 2.95 | 3.11 | 1.54 | 0.22 |
| 4" | mm | 100 | 80 | 49 | 101 | 13.5 | 74 | 30 | 5 | 17 | 2 | 132 | 115 | 122 | 52.5 | 5.5 |
| | in | 4.0 | 3.15 | 1.93 | 3.98 | 0.53 | 2.91 | 1.18 | 0.20 | 0.67 | 0.08 | 5.20 | 4.53 | 4.80 | 2.07 | 0.22 |

| Size | | S | T | W | BB | CC | DD | EE | GG | HH | JJ | MM | Weight |
|------|----|------|------|------|------|------|------|------|------|------|------|------|----------|
| 2.5" | mm | 2 | - | 14 | 68 | 72 | 63 | 36.5 | 61 | 3 | 50 | 91 | |
| | in | 0.08 | 1/4" | 0.55 | 2.68 | 2.83 | 2.48 | 1.44 | 2.40 | 0.12 | 1.97 | 3.58 | 0.66 lb. |
| 4" | mm | 3.5 | - | 22 | 107 | - | 101 | 48 | 75.5 | 5 | 59 | - | |
| | in | 0.14 | 1/2" | 0.87 | 4.21 | - | 3.98 | 1.89 | 2.97 | 0.20 | 2.32 | - | 2.43 lb. |

Recommended panel cutout is dimension D + 1.8 mm = 102.8 mm

Ordering information

Pressure gauge model / Nominal size / Scale range / Size of connection / Optional extras required
 Specifications and dimensions given in this leaflet represent the state of engineering at the time of printing.
 Modifications may take place and materials specified may be replaced by others without prior notice.



WIKAI Instrument Corporation
 1000 Wiegand Boulevard
 Lawrenceville, GA 30043
 Tel (770) 513-8200 Toll-free 1-888-WIKA-USA
 Fax (770) 338-5118
 E-Mail info@wika.com
 www.wika.com